



Friant Associates presents our newest line of panel systems



Friant's newest line of panel systems, Tiles™ is a premium frame and tile system with an 'A' grade fit, finish and detail and flexible design options. Materials such as glass, fabric, perforated metal and white board interplay to allow the greatest flexibility in creating a custom workstation.

Only 2-4 week lead time (based on product availability).



Available Fabrics, Surfaces and Trim:

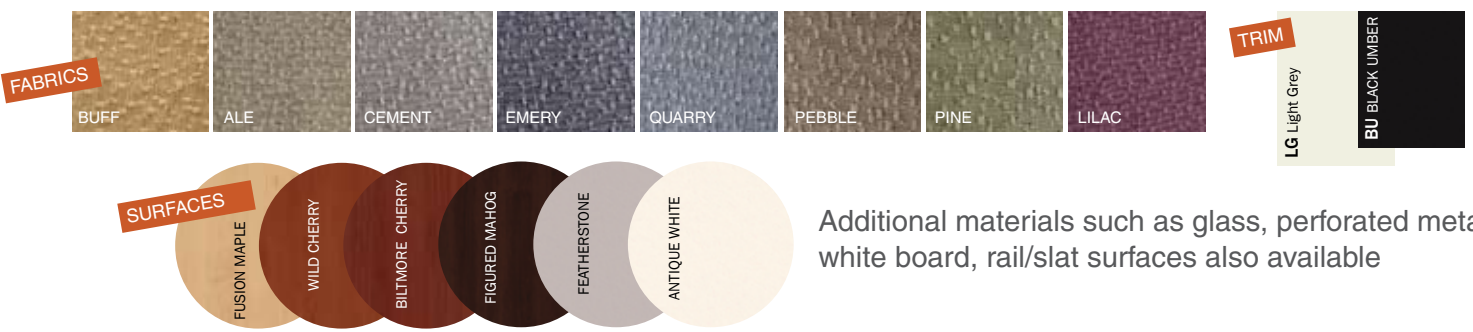

Additional materials such as glass, perforated metal, white board, rail/slat surfaces also available

Typicals

Tiles™ can be customized to suit your company's needs – now, and as you grow. Below are a few typical configurations ordered by our customers.

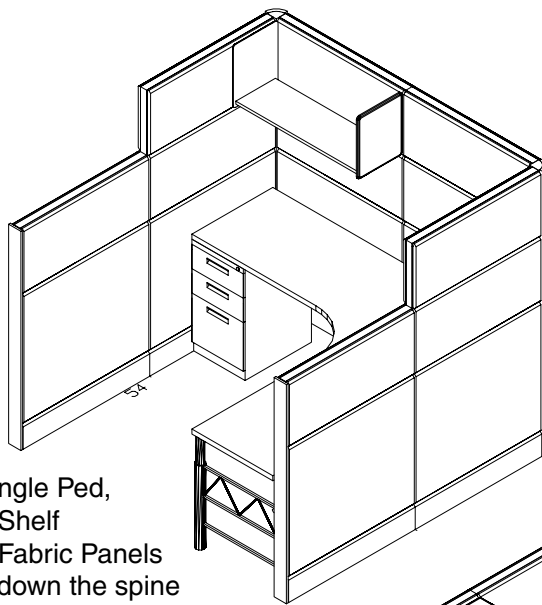

6x6, Single Ped,
Single Shelf
70/54" Fabric Panels
Power down the spine
2 Duplex per Station
Open Metal Leg

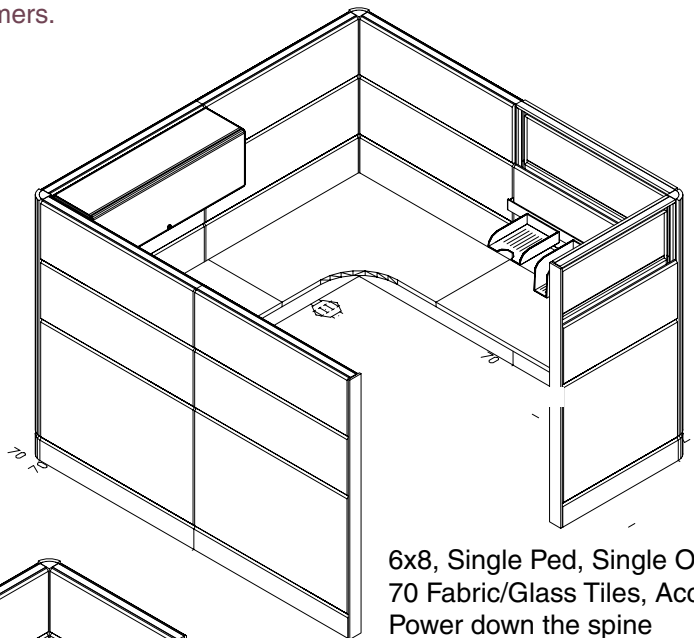

6x8, Single Ped, Single Overhead
70 Fabric/Glass Tiles, Accessories
Power down the spine
2 Duplex per Station

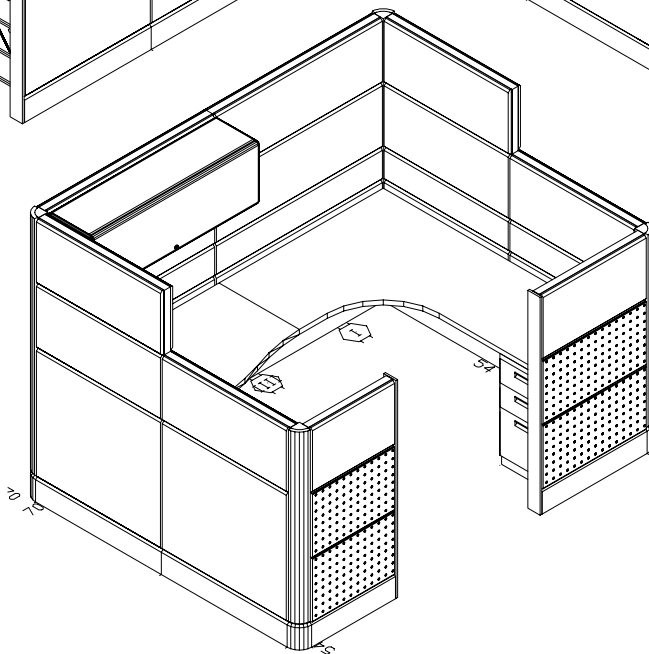

6x8, Single Ped, Single Overhead
70/54" Fabric/Metal Tiles
Power down the spine
2 Duplex per Station

For more information, contact Friant at (510) 535-5113



furnishing excellence™
www.friant.com

4901 E. 12TH STREET OAKLAND, CA 94601 • FAX: 510.535.5237 • 510.535.5113

FOB Oakland, CA